

WERK-BRAU CO., INC. PRODUCT AND INSTALLATION MANUAL

D-Lock Coupler
(Fully Automatic with Dual Pin Locking)
ISO 13031 Compliant



Serial No:

Model No:

Date Manufactured:

PROUDLY MANUFACTURED IN FINDLAY, OH





INTRODUCTION

P.O. Box 545 Findlay, Ohio 45839-0545
1-800-537-9561 *phone*
419-422-7207 *fax*
Werk-Brau.com

Thank you for your purchase. You have received a high quality D-Lock Coupler that will increase a machine's productivity and versatility by enabling the operator to quickly change from one attachment to another. If installed and maintained properly, it should provide years of service in a rugged environment.

TABLE OF CONTENTS

TITLE	PAGE
Safety Statement Guide	3
General Safety Precautions	3
Operating Procedures	5
Pre-delivery Check	6
Risk Assessment	7
Important Safety Information	9
Product Identification & Decals	10
Operation	12
Maintenance	21
Parts List	31
Warranty Policy	32

If at any time in the future, you require additional information on the D-Lock quick coupler or any aspects of its use, please do not hesitate to contact Werk-Brau Co., Inc.

SAFETY STATEMENT GUIDE

DANGER

Danger tags are used in major hazard situations where an immediate hazard presents a threat of death or serious injury to operator and anyone about.

WARNING

Warning tags are used to represent a hazard level between “Caution” and “Danger”, instead of the required “Caution” tag, provided that they have a signal word of “Warning,” an appropriate major message.

CAUTION

Caution tags are used in minor hazard situations where a non-immediate or potential hazard or unsafe practice presents a lesser threat of injury.

NOTICE

A notice label is used where equipment or property damage could result if the instructions are not followed properly.



This symbol by itself or used with a safety signal word throughout this manual is used to call your attention to instructions involving your personal safety or the safety of others. Failure to follow these instructions can result in injury or death.

GENERAL SAFETY PRECAUTIONS

DANGER

READ MANUAL PRIOR TO INSTALLATION

Improper installation, operation, or maintenance of this equipment could result in serious injury or death. Operators and maintenance personnel should read this manual as well as all manuals related to this equipment and the operating machine thoroughly before beginning installation, operation, or maintenance. FOLLOW ALL SAFETY INSTRUCTIONS IN THIS MANUAL AND THE OPERATING MACHINES MANUAL.

WARNING

READ AND UNDERSTAND ALL SAFETY STATEMENTS

Read all safety decals and safety statements in all manuals prior to operating or working on this equipment. Know and obey all OSHA regulations, local laws and other professional guidelines for your operation. Know and follow good work practices when assembling, maintaining, repairing, mounting, removing or operating this equipment.

DANGER

KNOW YOUR EQUIPMENT

Know your equipment’s capabilities, dimensions and operations before operating. Visually inspect your equipment before you start, and never operate equipment that is not in proper working order with all safety devices intact. Check all hardware to assure it is tight. Make certain that all locking pins, latches, and connection devices are properly installed and secured. Remove and replace any damaged, fatigued or excessively worn parts. Make certain all safety decals are in place and are legible. Keep decals clean, and replace them if they become worn and hard to read.

NOTICE

PROTECT AGAINST FLYING DEBRIS

Always wear proper safety glasses, goggles with a face shield when driving pins in or out or when any operation causes dust, flying debris, or any other hazardous material.

WARNING

LOWER OR SUPPORT RAISED EQUIPMENT

Do not work under raised booms without supporting them. Do not use support material made of concrete blocks, logs, buckets, barrels or any other material that could suddenly collapse or shift positions. Make sure support material is solid, not decayed, warped, twisted, or tapered. Lower the boom(s) to ground level or onto block(s). Lower the boom(s) and attachment(s) to the ground before leaving the cab or operator’s station.

GENERAL SAFETY PRECAUTIONS - CONT'D

WARNING

USE CARE WITH HYDRAULIC FLUID PRESSURE

Hydraulic fluid under pressure can penetrate the skin and cause serious injury or death. Hydraulic leaks under pressure may not be visible. Before connecting or disconnecting hydraulic hoses, read your operating machines operator's manual for detailed instructions on connecting and disconnecting hydraulic hoses or fittings.

- Keep unprotected body parts, such as face, eyes, and arms as far away as possible from a suspected leak. Flesh injected with hydraulic fluid may develop gangrene or other permanent disabilities. Wear safety glasses, protective clothing, and use a sound piece of cardboard or wood when searching for hydraulic leaks. **DO NOT USE YOUR HANDS**
- If injured by injected fluid, see a doctor at once. If your doctor is not familiar with this type of injury, ask him to research immediately to determine proper treatment.

WARNING

DO NOT MODIFY MACHINE OR ATTACHMENTS

Modifications may weaken the integrity of the attachment and may impair the function, safety, life and performance of the attachment. When making repairs, use only the manufacturer's genuine parts, following authorized instructions. Other parts may be substandard in fit and quality. For loaders, never modify any ROPS (Roll Over Protection System) equipment or device.

!!!Any modifications must be authorized in writing by Werk-Brau or the manufacturer!!!

DANGER

NOTICE

SAFELY OPERATE THE EQUIPMENT

Do not operate equipment until you are completely trained by a qualified operator in how to use the controls, know its capabilities, dimensions, and all safety requirements.

See your operating machines manual for these instructions.

- Keep all step plates, grab bars, pedals, and controls free of dirt, grease, debris, and oil.
- Be sure that all bystanders are out of harm's way when operating.
- Do not allow riders on the attachment or operating machine
- Do not operate the equipment from anywhere other than the correct operators position.
- Never leave equipment unattended with the engine running or with this attachment in a raised position.
- Do not alter or remove any safety feature from the operating machine or this attachment.
- Know your work site safety rules as well as traffic rules and flow. When in doubt on any safety issue, contact your supervisor or safety coordinator for an explanation.
- Hammers must be used in vertical position
- Pulverizes, Cutters, Shears and Concrete Busters are not approved.



SAFELY MAINTAIN AND REPAIR EQUIPMENT

- Do not wear loose clothing, or any accessories that can catch in moving parts. If you have long hair, cover or secure it so that it does not become entangled in the equipment.
- Work on a level surface in a well-lit area.
- Use properly grounded electrical outlets and tools.
- Use the correct tool for the job at hand. Make sure tools are in good condition.
- Wear all protective equipment specified by the tool manufacturer.

OPERATING PRECAUTIONS

WARNING

DO NOT IMPROPERLY USE COUPLER

This coupler is designed to couple attachments and not for any other use.

DANGER

BE AWARE OF SURROUNDING UTILITIES

Operator must be aware of all utility line and overhead electrical lines. Operations must be able to clear all lines safely.

NOTICE

DANGER

BE AWARE OF OVERHEAD DANGER

Operator must be aware of all possible overhead dangers that are within the range of motion of the operating machine.

WARNING

DO NOT OPERATE WITH A LOOSE ATTACHMENT

Visually check the coupler to verify attachments are secure and lock is fully engaged and that the center to center of the attachment matches up with the coupler range.

WARNING

PINCH POINTS

Personal injury could result from the careless misuse of this coupler. Keep hands and body parts clear of the coupler when it's in the process of hooking up to an attachment. Be sure the machine is off and the attachment is on the ground prior to making adjustments.

NOTICE

COUPLER EXTENDS TIP RADIUS

Notice adding a coupler to machine extends the tip radius. This can cause clearance issues on some machines making it possible for a coupled attachment to come into contact with the machine, causing damage.

DANGER

DAILY OPERATIONAL USE

Fully engage the coupler every time before moving or using attachments.

Hammers must be used in vertical position.

Pulverizes, Cutters, Shears and Concrete Busters are not approved.

Installation completed by:

Company:	
Name:	
Date:	
Excavator make and model:	
Coupler Serial #	
End user name:	
End user phone number:	
End user address:	
End user email address:	

Lock circuit pressure checked at:	PSI
Unlock circuit pressure checked at:	PSI
Hose routings checked and abrasion free throughout full crowd movement:	
All supplied attachments locked and unlocked from coupler:	
All hydraulic connections, clean, tight and leak free:	
Please specify type and brand of control valve fitted	

NOTES:

This risk assessment form is supplied as a guide only. It is the responsibility of the owner / operator to ensure that this equipment is operated in a safe manner and complies with all relevant compliance regulations.

Location of risk assessment:	Date:
------------------------------	-------

Typical hazards associated with this equipment	Personnel affected			
Type	Indicate in table below			
	Operator	Site Personnel	Service Personnel	General Public
Changing Attachments				
Is there a copy of the operations manual in the machine cabin?				
Has the operator been correctly trained for use with this particular coupler and verified?				
Is the operator aware they should not operate this machine unless they are satisfied that the coupler is in a safe condition?				
Are all personnel aware that they must not remain near attachments during attachment changes?				
Falling objects				
Are all personnel aware that they must not position themselves under attachments or suspended loads?				
Lifting equipment				
Is the SWL rating of the equipment clearly displayed?				
Does all lifting equipment carry a current SWL certification?				
Warning devices and Decals				
Are all safety and operations decals clearly displayed?				
Does the operator check that the equipment warning devices are operational daily?				
Equipment malfunction				
Is there a checklist of daily, weekly, monthly inspections?				
Is there a record of all service / repair work?				

Other hazards identified:	
Plant & machinery movement	
Warning devices on plant and equipment	
Noise	
Environment	

Assessed by:	Reported to:
Name	Name
Date	Date

Daily pre start check list:

Operators Name:	Date:
-----------------	-------

Coupler serial number:	S	M	T	W	T	F	S
Check all attachment pin retainer bolts and nuts for tightness.							
Check attachments for pin wear							
Check all hydraulic hoses and fittings for any leaks or wear							
Clean away any material build up around cylinder guide ways, spring apertures and the pin engagement surfaces.							

Weekly pre start check list:

Thoroughly clean coupler	Week ending:
Check Coupler for evidence of fatigue, weld failure or stress. Do not operate with a cracked weldment.	
Repeat daily checks above.	

Operators Name & Signature:	Managers Name & Signature:

IMPORTANT SAFETY INFORMATION

The D-Lock range of Hydraulic Couplers comply with ISO 13031.

Remember that on any job, YOU are the key to safety. Safe practices not only protect the people around you; they are also your own best protection. Study this section and any relevant manufacturer's operation manuals covering your equipment. Read all warning and caution instructions prior to use.

1. This manual must be **READ** and **UNDERSTOOD** before any installation and operation work begins. A copy must be kept in the operator's cabin for ongoing use.
2. Operators should note that the use of a quick coupler may affect the machine's breakout force and balance. This may also result in attachments being able to come into contact with the boom and/or the operator's cabin.
3. Werk-Brau D-Lock couplers are designed for use with Werk-Brau Approved attachments **ONLY!** Approval must be obtained for use with non Werk-Brau attachments.
4. All D-Lock couplers must be connected and installed in full compliance with this manual. Any variations may cause the coupler to operate in an unsafe manner and/or void the warranty.
5. Due to the self-tightening and automatic wear compensation features of this coupler it is recommended that the locking cylinder be disengaged at the end of each day.
6. The D-Lock quick coupler is designed to take up wear, however if mounting pin wear exceeds 5% of the original diameter, immediately replace implement pins.
7. All excavator operators should familiarize themselves with all coupler/attachment combinations before attempting to operate the coupler. This should include, but be not limited to, practicing engaging and disengaging each attachment. Furthermore when new attachments are added to the machine's fleet, the operators should proceed with the same "familiarization" process before it is used on the job site.
8. Hammers must be used in vertical position.
9. Pulverizes, Cutters, Shears and Concrete Busters are not approved.
10. Never use the Coupler as a prying tool.
11. Never use the Coupler as a clamping device.
12.  **In the event of a loss of engagement failure, the Jaw Locking Pawls and compression units **MUST BE REMOVED AND REPLACED!****



PRODUCT IDENTIFICATION AND DECALS

All D-Lock Couplers are supplied with an ID plate attached as shown in the images below. In addition, a serial # is stamped into the top edge of the Left Hand mounting plate.

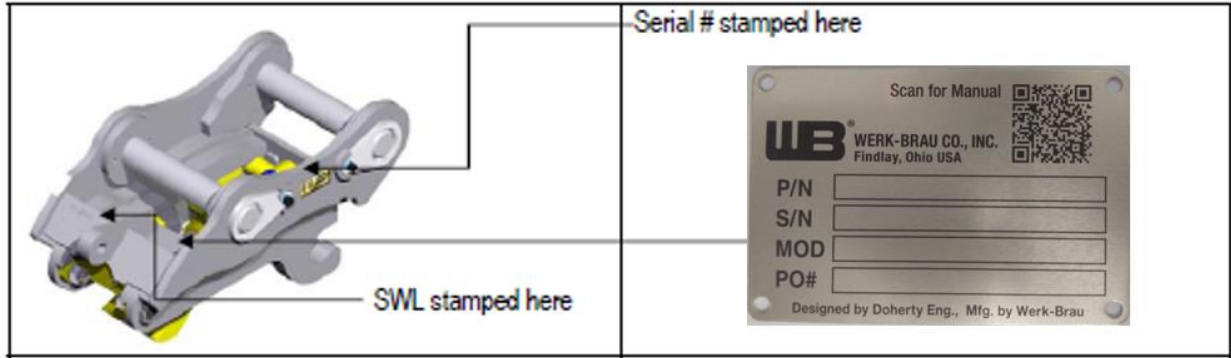

It is recommended that a copy of these details be kept in the office for future reference.



Always provide these details when contacting Werk-Brau Co., INC. for Service or Parts.

The DECALS pictured below are included with your coupler and should be installed in the operator cab prior to any attachment use. These must be clearly visible from the operating position and be maintained in a clean and legible condition. Replacements for damaged or missing decals may be obtained from the Werk-Brau parts department.

ENGAGE ATTACHMENT

1 DISENGAGE coupler switch



2 Fully curl and hold for 5 SECONDS

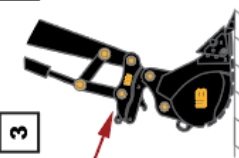

3 DISENGAGE coupler switch

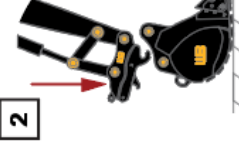

4 Mechanically check coupler connection on ground

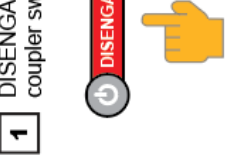

5 ENGAGE coupler switch

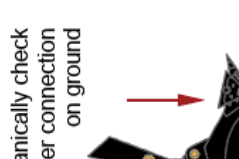

6 Fully curl and hold for 5 SECONDS



7 VISUAL CHECK ENGAGE INDICATORS



8 Mechanically check coupler connection on ground



⚠ DANGER



CRUSH HAZARD.
Attachment may drop without warning if not properly attached. Consult owners manual for proper installation procedures. Failure to comply could result in death or serious injury.

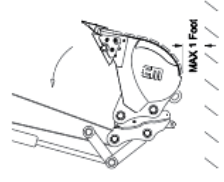

Attachment must be disengaged in the fully curled position. NEVER activate switch in any other attachment position.



Hammers must be used in vertical position. Pulverizers, Cutters, Concrete Busters and Shears are **NOT Approved**

⚠ WARNING

This machine is fitted with a quick coupler. This may lead to interference with the machine.

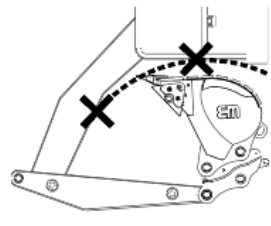

DECAL-DL-OP-REV-C

ENGAGE ATTACHMENT

- 1** Fully curl coupler
- 2** DISENGAGE coupler switch
- 3** Fully curl and hold for 5 SECONDS
- 4** Fully curl and hold for 5 SECONDS
- 5** DISENGAGE coupler switch

DISENGAGE ATTACHMENT

- 1** Fully curl coupler
- 2** DISENGAGE coupler switch
- 3** Fully curl and hold for 5 SECONDS
- 4** Fully curl and hold for 5 SECONDS
- 5** DISENGAGE coupler switch



WERK-BRAU

For More Information & Operation Manual



WORK SAFE

"EVERYBODY MATTERS"

The locking system is based on a well proven sliding jaw design that incorporates several patented features to ensure safe and secure operation. The sliding jaw acts as a wedge on the rear bucket pin and compensates for allowable component wear. The coupler intentionally needs unlocked to release attachments. If there is a loss of hydraulic pressure, the coupler jaw will stay engaged which eliminates unintentional or accidental loss of engagement.

Weekly operator maintenance and cleaning is recommended to ensure no excessive build-up of material on the interior or pin engagement surfaces.

IMPORTANT INSTALLATION NOTES

- Due to the large number of Excavator Makes and Models available, it is not possible to provide a rigid set of installation instructions that will cover every situation. Modern Excavator control systems are complex and sophisticated. Hydraulic connections must be carried out with care to ensure the manufacturer's warranty is not voided. It is therefore extremely important that only appropriately qualified and experienced persons carry out the installation. It is **STRONGLY RECOMMENDED** that the excavator dealer be consulted to ensure the hydraulic connections are correctly made.
- Installation personnel must be competent and experienced in this type of work. All requirements listed in this manual must be fully understood and complied with.
- Best hydraulic practice will be used to ensure that all components remain clean and free of contamination and that all hoses are suitably routed and armored to prevent, crushing, pinching or chaffing damage.
- No changes to the host machine's control systems should be made without express agreement by the manufacturer and or distributor.
- All current Health and Safety Regulations pertaining to this installation and subsequent operation must be complied with.
- Failure to comply with these guidelines may cause equipment damage and/or void any applicable warranty. Contact Werk-Brau for additional assistance if required.

FITTING THE COUPLER

1. Remove any existing attachments from the machine. Some models of Werk-Brau couplers are supplied with hardened mounting pins. If these are not supplied, the coupler is mounted using the OEM pins which were supplied with your machine.



2. **NOTE:** Hardened pins **MUST** be used for this application. **DO NOT** use non hardened attachment pins.
3. **CLEAN** all bores and pin surfaces, pre-lubricate pins with grease and set aside on a clean surface.
4. Carefully align the link arm between the two bosses, which are furthest from the cab of the machine. Ensure the O-rings are correctly positioned (if applicable) and fit one pin.

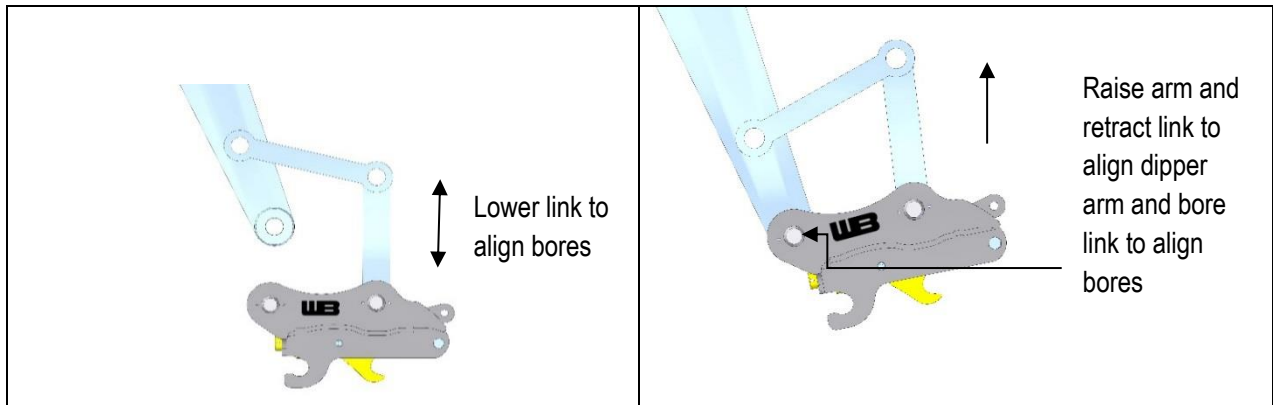

5. You can now lift the coupler off the ground and use the crowd and arm controls to accurately line up the main dipper arm bore. Position the O-rings (if applicable) and fit the second pin.
6. Ensure the pin retaining bolts are fitted and tightened. Use nyloc lock nuts or supplied bolts for Werk-Brau supplied pins.
7. Grease both pivot points as required.
8. Using the excavator hydraulics, carefully crowd the quick coupler to the extremes of the crowd travel and check that there is adequate clearance between the coupler and the dipper arm surfaces and linkages.

Note

Your coupler may be supplied with optional front clipper plate profiles. These are recommended, but not essential, and they can be welded to either side plate to take up the gap between the coupler and attachment. Locate by offsetting approximately 10mm from the front pin (see below).

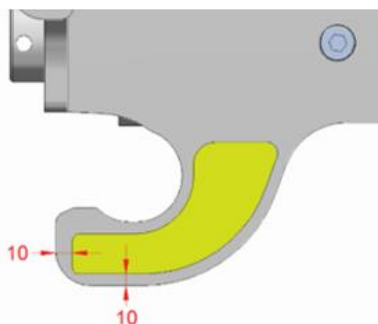

CONNECTING THE COUPLER LOCK CIRCUIT

ELECTRICAL & HYDRAULIC INSTALL

Refer to one of the following installation documents depending on the hose kit you received.

1. BR# & SH# for machine specific hose kit.
2. Any other hose kit must be approved in writing by Werk-Brau.



FINAL CHECK

1	Verify all fittings and fasteners are tight and secure.	
2	Check the entire system for leaks.	
3	Move the Coupler through its entire motion slowly checking for: Hose chaffing Proper hose lengths Any type of mechanical interference.	
4	Test the D-Lock switch, ensure alarm sounds and light flashes when in unlock mode.	
5	Attach and detach all attachments to be supplied with the machine and ensure coupler locks securely.	
6	Ensure that all product and cab decals are correctly fitted and visible.	
7	Complete Warranty registration and Pre-delivery forms and return to Werk-Brau to activate product warranty.	
8	Ensure the manual (or a copy) is kept in the operator's cab. Additional copies of this manual are available in hard copy or electronic form from Werk-Brau Engineered Attachments.	

LOCKING / UNLOCKING PROCEDURE



The D-Lock range of Quick hitch couplers comply with ISO 13031 – Quick Hitch (Couplers) and requires a particular procedure for successful locking and unlocking which may vary from other couplers. **It is important that all operators fully understand the correct procedure as described and illustrated below.**



CHECK ALL ATTACHMENTS BEFORE USE TO ENSURE THEY ARE CORRECT FOR THE COUPLER:

The Coupler is fitted with an ID tag which states the pin diameter(s) it is designed for, ensure all attachments are checked before use.





Example on how to check:

Check Pin Diameter	Check Pin Centers	Check Internal Width
		
<p><i>Note, Internal width should not exceed the width of the coupler more than 4mm per side, If coupler is used on Under cutters, rock saws or any other attachment which has a significant side load, the coupler MUST be a tight fit.</i></p>		

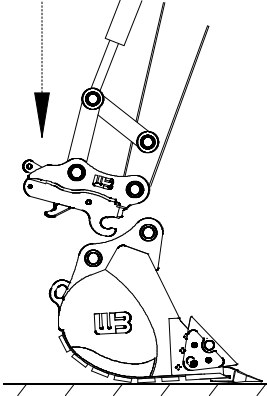
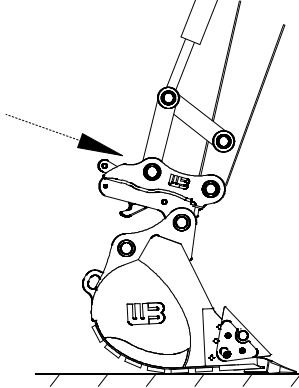

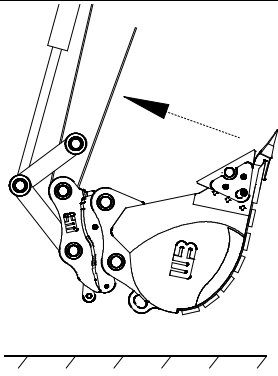
TO ATTACH/ENGAGE/LOCK ATTACHMENTS: WITH WB CONTROL BOX

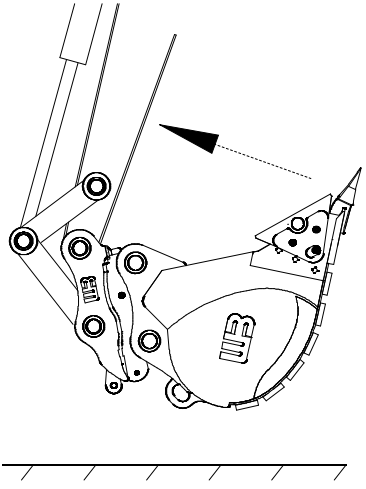
<p>STEP 1</p> <p>Place coupler in the fully curled/crowded position. Press and hold the green “Activate” button for 3 seconds. Release the “Activate” button and press and hold the red “Disengage Mode” button for 2 seconds—the buzzer will sound. Hold the bucket crowd lever for approx. 3-5 seconds to allow the hook to fully retract. Visually inspect to check the jaw is fully retracted.</p>	
<p>STEP 2</p> <p>After ensuring that the jaw is fully retracted, place the coupler above the attachment.</p>	
<p>STEP 3</p> <p>Curl the coupler to engage the front pin.</p>	

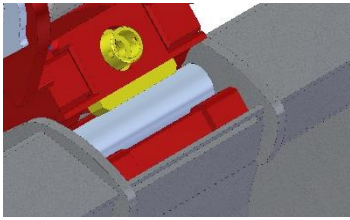
<p>STEP 4</p> <p>Continue to curl the coupler until the attachment is lifted off the ground</p>	
<p>STEP 5</p> <p>Fully curl/crowd the bucket. Press the “Engage Mode” button. Hold the bucket crowd lever for approx. 3-5 seconds to allow the jaw to fully engage and clamp the bucket pin.</p> <p> DANGER – If the bucket/attachment pins have not been correctly engaged, the jaw MUST NOT be retracted. This could cause the bucket to be unintentionally released from the coupler and could result in machine damage or personal injury. Please refer to step 6 for corrective action.</p>	
<p>STEP 6</p> <p>Visually inspect and check that the rear jaw is engaged.</p> <p>If the front lock indicator is not visible:</p> <ol style="list-style-type: none"> Bring the attachment to full machine curl. Press and hold green button for three seconds. Press and hold red “disengage mode” button for 2 seconds. Hold crowd on relief for 3-5 seconds Press yellow “Engage Mode” button and hold bucket crowd lever for 3-5 seconds to allow jaw to fully engage. Visually inspect again. 	 

STEP 7

If it is not possible to view this from the cab then the operator must get out of the cab and stand in a safe place to visually inspect before operating the machine.



STEP 8

To ensure that the bucket pins are securely held by the coupler, apply pressure to the bucket by rotating it against the ground and away from the machine before operation.

It is highly recommended to complete this step prior to using any attachments to confirm it has been properly engaged.

If the bucket is not correctly attached, repeat the sequence from step 1.

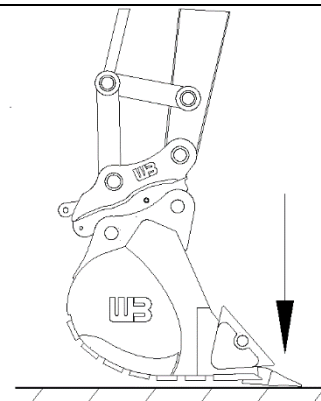

TO RELEASE/DISENGAGE/UNLOCK ATTACHMENTS: WITH WB CONTROL BOX

STEP 1

Place bucket and coupler in fully curled/crowded position. Press and hold the green “Activate” button for 3 seconds. Release the “Activate” button and press and hold the red “Disengage Mode” button for 2 seconds—the buzzer will sound. Hold the bucket crowd lever for approx. 3-5 seconds to allow the hook to fully retract.



WARNING – Do not release or change the bucket near any person or in any areas that may result in an accident or injury occurring. The switch should be in the **engage** or **off** position at all times, except during bucket changing.

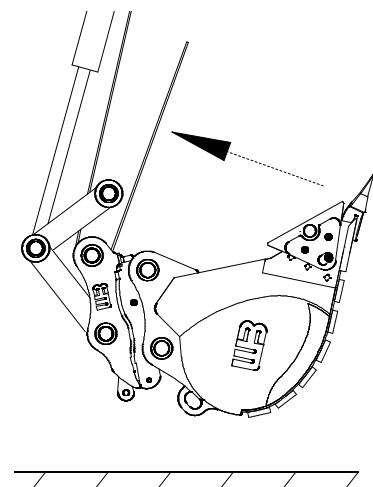

STEP 2

Once the jaw is fully retracted, lower the attachment to ground and slowly curl the coupler back to release the rear bucket pin.

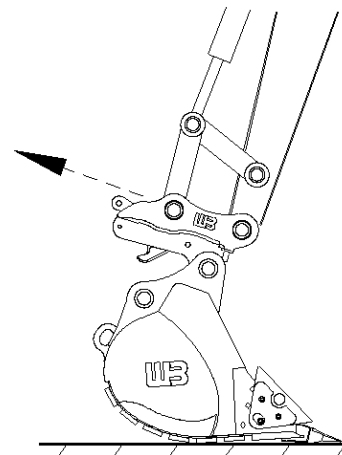

Step 3

Lift the dipper arm until the coupler has disengaged the front bucket pin. The attachment is now safety disengaged.

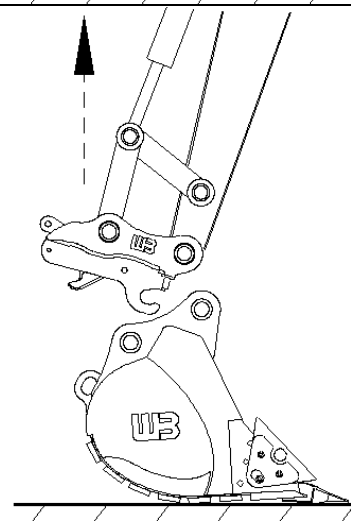

HANDY TIPS

1. Your Coupler should be unlocked on a daily basis to ensure satisfactory operation. It is particularly important to unlock your coupler daily when using hammers or digging in hard ground as the constant vibration can cause the wedged surfaces to become very tight.
2. If your machine is to remain inactive for an extended period, WB suggests the attachment be released to eliminate the possibility of seizing.
3. Keep your coupler clean. Buildup of material in the pin contact areas will affect the locking effectiveness and may cause unlocking problems.
4. The operator may experience slow or unexpected movement of functions when operating with cold hydraulic oil. Likewise, damage to the hydraulic components may result due to cold oil. Make sure to warm up hydraulic system before operation.



OPERATIONAL SAFETY NOTES:



Site Personnel must stay clear when engaging and disengaging a bucket or an attachment.

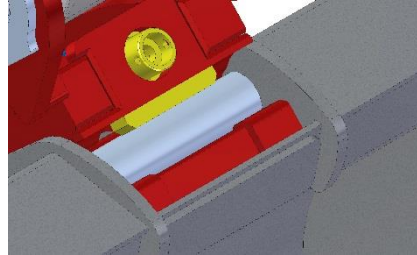

If Yellow D-Lock indicator is not visible, the coupler is incorrectly attached. **DO NOT OPERATE.** Lower to the ground and carefully check for obstructions



If alarm continues to sound after engaging to LOCK there is an electrical fault. **DO NOT OPERATE THE MACHINE** until this is rectified.

Due to the self-tightening and automatic wear compensation features of this coupler it is recommended that the locking cylinder be disengaged at the end of each day.



USING THE LIFTING POINT

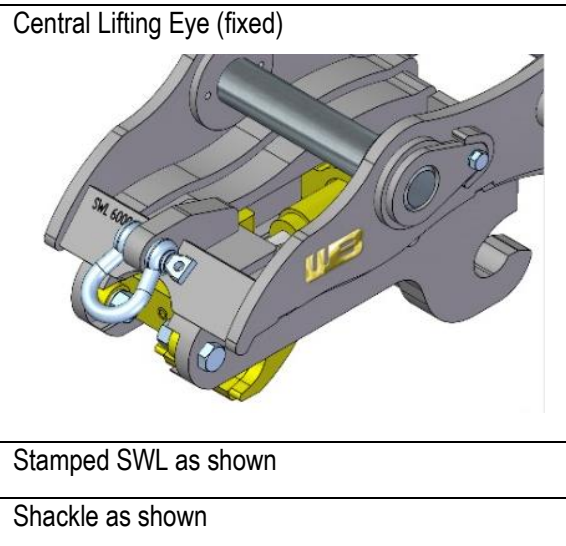

These lifting points are designed for use only with certified Bow Shackles. No other devices are to be used.



LIFTING SAFETY NOTES



Use **ONLY A CERTIFIED BOW SHACKLE** through the lifting point aperture.

1. The safe working load (SWL) in LBS is stamped adjacent to the lifting point and **MUST NOT BE EXCEEDED** under any circumstances. Note this rating must be checked against the machines lift chart ratings and the lowest figure used in all situations.
2. ALWAYS remove the attachment from the coupler before lifting.
3. Fully extend the crowd cylinder when lifting.
4. Do not attach lifting chains or slings to any other part of the coupler
5. NEVER allow chains to push against sliding jaw.

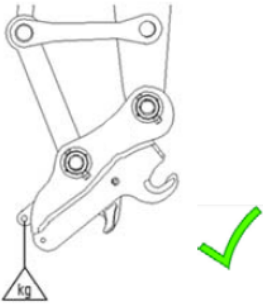
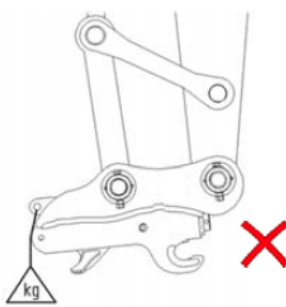
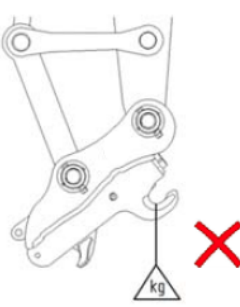
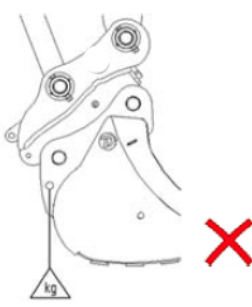

LIFTING SAFETY WARNING

Inspect the lifting eye for any wear or defects any time before use. The lifting eye **MUST** be formally checked every 6 months for wear and damage. If the lifting eye wear is outside the tolerances shown in the chart below, do **NOT** use. Also reference the image below for recommended lifting practices.

			
Lift when vertical and with the jaw fully retracted	Do not lift with jaw extended or with hitch horizontal	Do not lift from Open C	Do not lift from attachment
	<ul style="list-style-type: none"> • Only use the lift eye on the D-Lock coupler • Only lift with the D-Lock coupler in the vertical position • Fully retract jaw before lifting with the D-Lock coupler • Do not lift from any attachment connected to the coupler • Do not exceed the lifting eye capacity (SWL stamped next to lift eye) • Do not exceed the rated lifting capacity of the machine • Use in a safe manner at all times 		



Jaw Connection Wear and Explanation

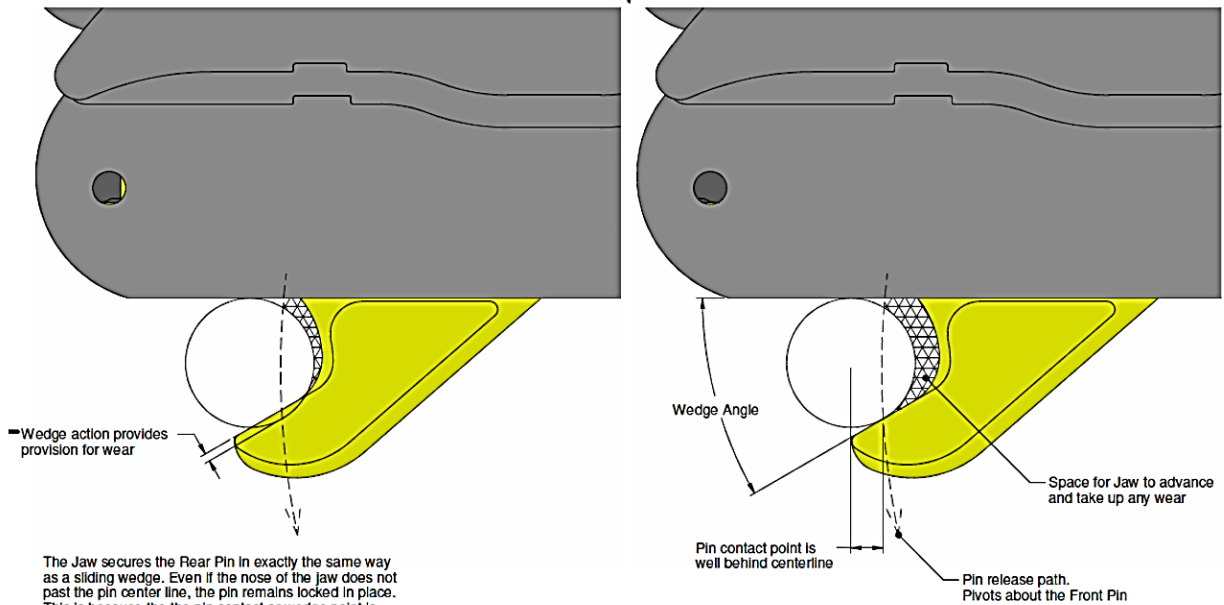

The Jaw secures the Rear Pin in exactly the same way as a sliding wedge. Even if the nose of the jaw does not past the pin center line, the pin remains locked in place. This is because the the pin contact or wedge point is well behind the pin center line.

The space between the Jaw "hook" and the pin allows the Jaw to extend to take up any wear. This ensures the pin remains tightly wedged at all times.

When the Rear Pin is released it pivots down in an arc about the Front pin.



LIFTING EYE WEAR LIMIT – EVERY 6 MONTHS OR 1000 HRS (whichever comes first)

The lifting eye **MUST** be formally checked every six months for wear or damage, if the lifting eye wear is outside the tolerances shown in the chart below, do not use.

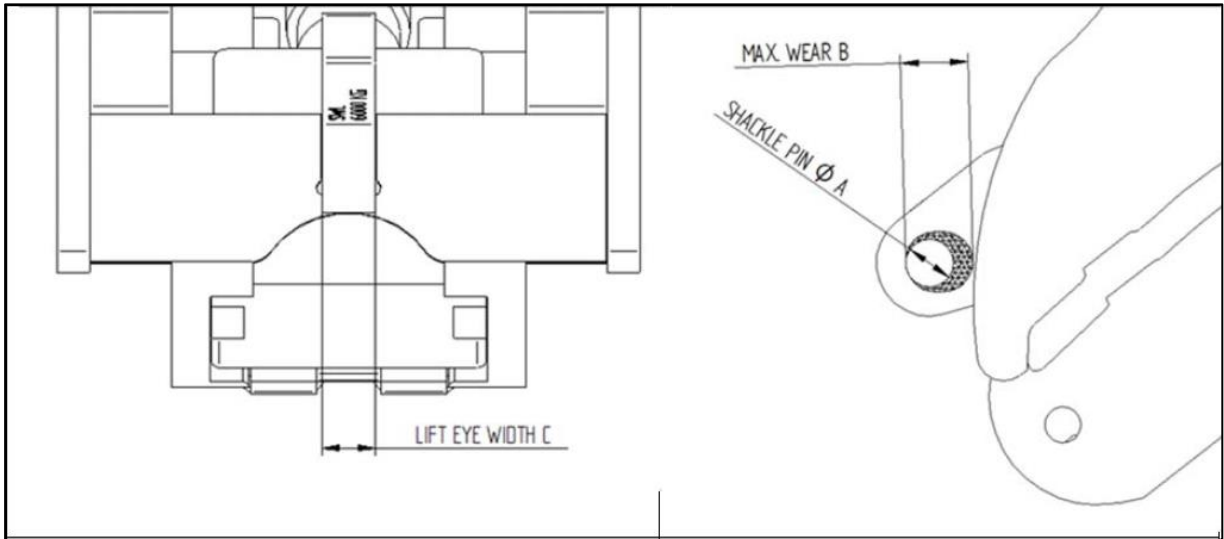

Lift Point Limits Table:

Shackle Pin ϕA (mm)	Max. Wear B (mm)	Lift Eye Width C (mm)	Coupler Model	SWL
16	19	16	HD035	
19	22	19	HD055	
22	26	25	HD080	
52	62	32	HD140	
52	62	38	HD180/240/250	
52	62	50	HD350	
58	69	50	HD450	



D-LOCK WEAR LIMITS – EVERY 6 MONTHS OR 1000 HRS (whichever comes first)

The D-Lock quick coupler range **MUST NOT** be used if the wear limits below are exceeded:

Pin Size (mm)	WL 1 Open C (mm)	WL 1 Open C Gauge No.	WL 2 Front Lock (mm)	WL 3 Attachment Pins (mm)
40	42	CG-40	37	38
45	47	CG-45	41	43
50	53	CG-50	45	47
55	58	CG-55	50	52
60	63	CG-60	55	57
65	69	CG-65	60	61
70	74	CG-70	65	66
80	84	CG-80	74	76
90	95	CG-90	83	85
100	105	CG-100	92	95
110	114	CG-110	102	104
120	126	CG-120	111	114
130	137	CG-130	120	123

How to check wear limits

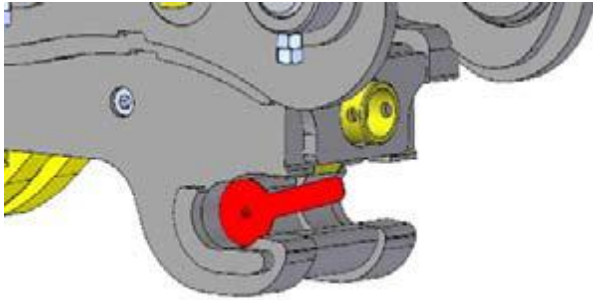
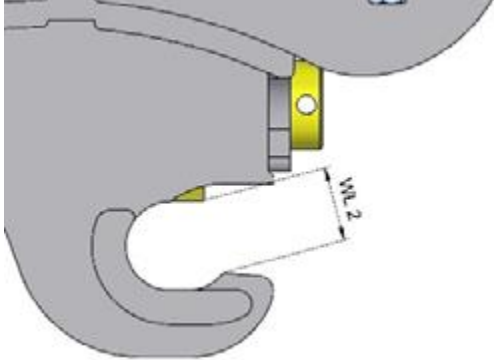
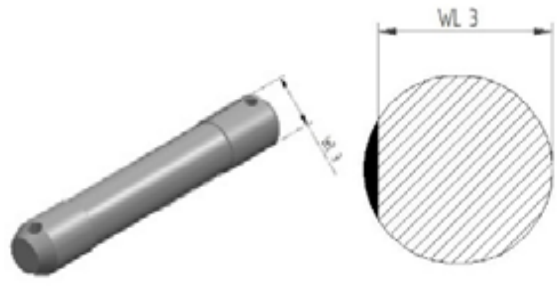
	<p><u>Open C (WL 1)</u></p> <p>Fully retract jaw so that front lock is in the disengaged position. Try fitting a test gauge (available from your D-lock dealer) into the open C by rolling into the base of the C from the front. If the gauge fits all the way into the back of the open C, then the wear limit has been reached and the open C must be built back up to the original diameter.</p>
	<p><u>Front Lock (WL 2)</u></p> <p>Fully extend jaw so that front lock is in the locked position. Measure from point to point as shown. If the measurement exceeds that in the table then the lock on the cylinder or the open C must be built up back to original dimensions.</p>
	<p><u>Attachment Pins (WL 3)</u></p> <p>The diameter of the pins of the attached implement should be checked as per below. Measure for both wear on the circumference and also any flat spots. Any pins measuring undersize as listed should be replaced.</p>



OEM mounting pin diameters should be checked against the supplier's recommendations. Replace pins if required.

JAW WEAR:

Inspect the contact surfaces of the Jaw. If there is evidence of the rear pin contacting the radial surface of the jaw, the wear limit has been reached and further inspections listed below must be made.

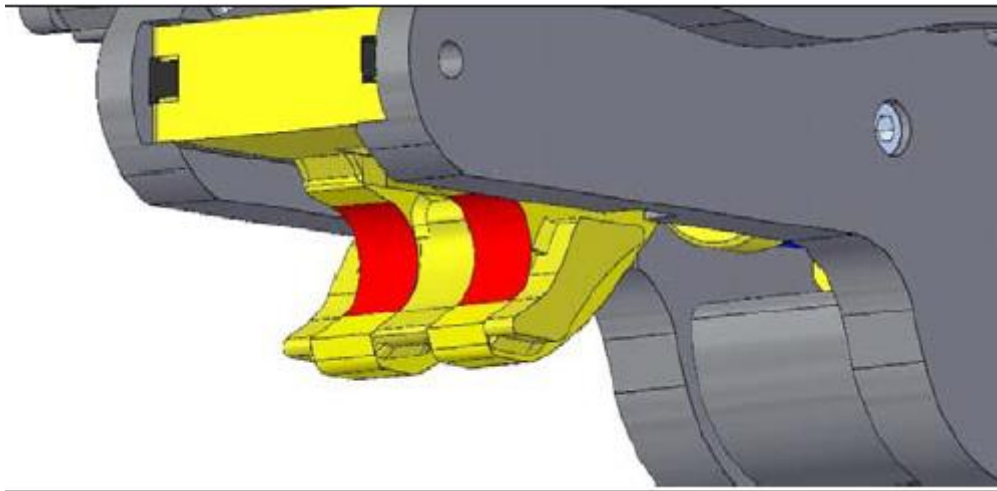

There are three wear areas that could be causing contact. It may be one area that is worn excessively or any combination of all three areas. All three areas should be checked and rectified if the below wear limits are exceeded.

Pin Size (mm)	WL 4 Body Rear Pin Surface (mm)	WL 5 Jaw Contact Surface (mm)	WL 6 Jaw Rails (mm)
40	2	14	3
45	3	12	3
50	3	26	3
55	3	26	3
60	3	18	4
65	4	28	4
70	4	21	4
80	4	25	4
90	5	32	5
100	5	39	5
110	6	32	5
120	6	40	5
130	7	43	5

How to check wear limits

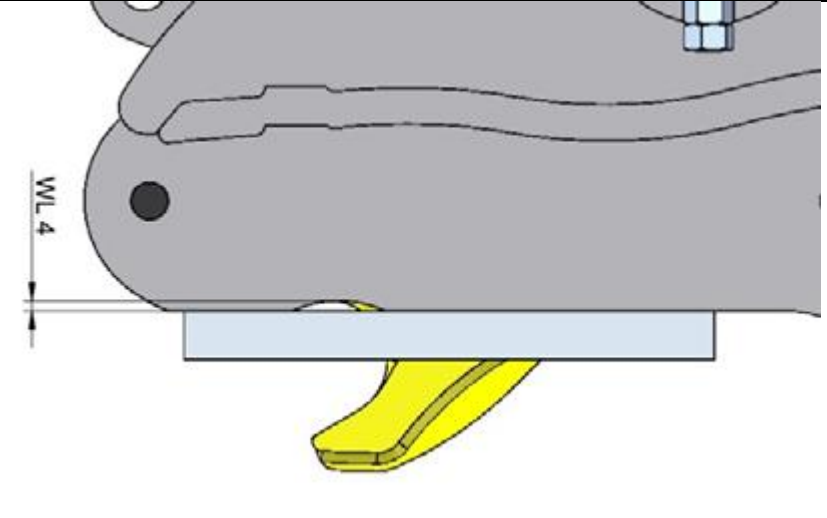
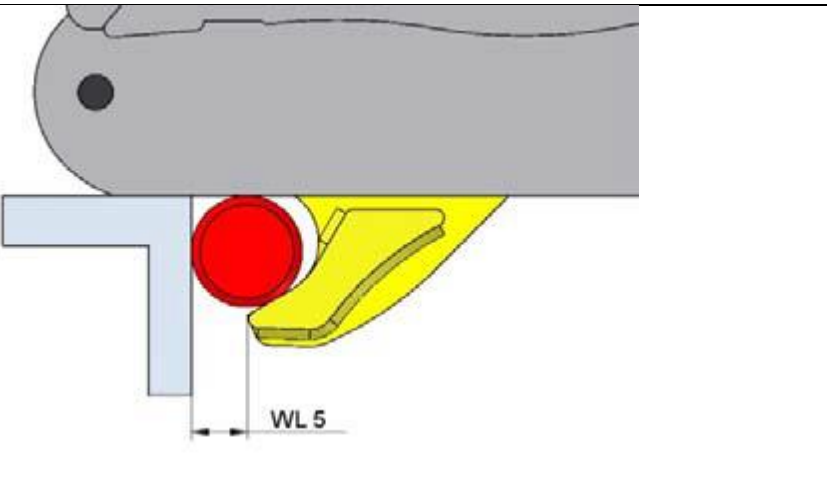
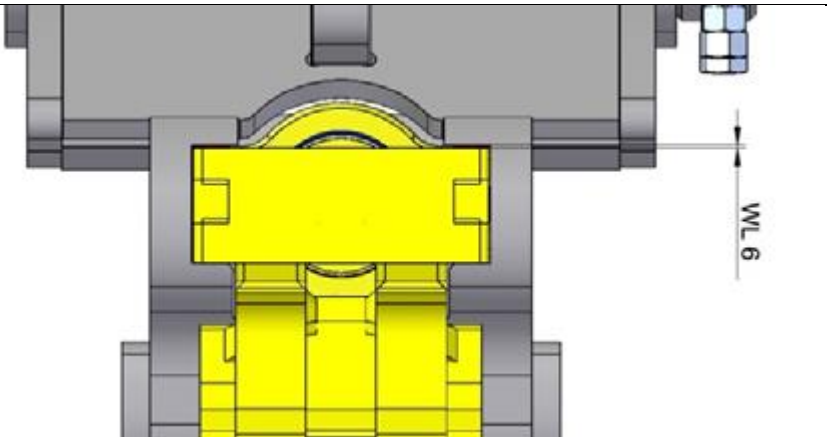
	<p><u>Body Rear Pin Surface (WL 4)</u></p> <p>Place straight edge along rear pin contact surface. Measure any gap between straight edge and surface. If the wear limit is exceeded the surface must be built up and ground back to original dimension.</p>
	<p><u>Jaw Contact Surface (WL 5)</u></p> <p>Place a square between rear pin contact surface and pin. Measure dimension and if it is less than the wear limit then the contact face of the jaw must be built up to original dimensions.</p>
	<p><u>Jaw Rail Clearance (WL 6)</u></p> <p>Measure the distance from the top of the jaw to the top edge of the jaw slot. If the gap exceeds the dimension shown then additional checks must be made (see Jaw Rail Checks).</p>

Jaw Rail Checks

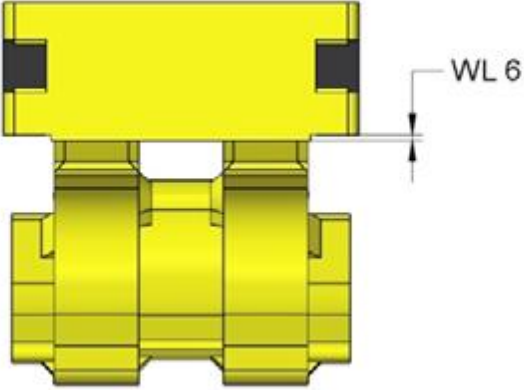
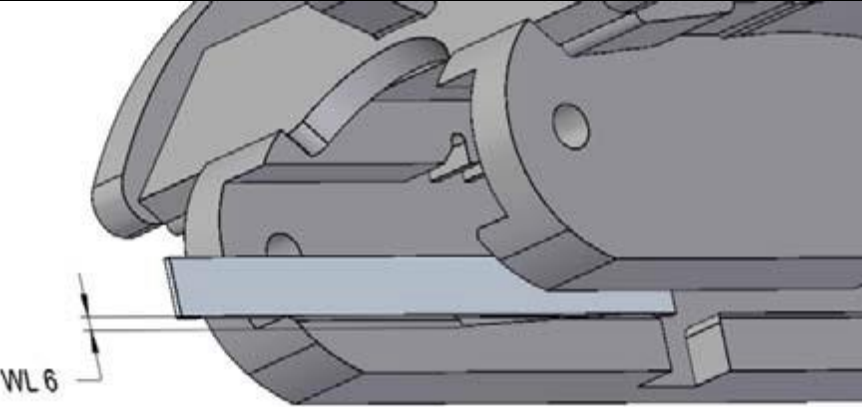
	<p><u>Jaw Check</u></p> <p>Remove jaw from hitch body. Inspect jaw base plate for any grooving on the underside. If the grooving exceeds the WL 6 limit the jaw base plate must be built up and ground back to original dimensions.</p>
	<p><u>Jaw Rail Check</u></p> <p>Remove jaw from hitch body. Place a straight edge along the lower rail surface. If there are any gaps that exceed the WL 6 limit then the hitch body must be taken out of service.</p>



DAILY PRESTART CHECKS

1. Disengage attachment from coupler.
2. Check all attachment pin retainer bolts and nuts for tightness.
3. Check attachments for pin wear - The D-Lock Quick Coupler is designed to take up wear, however if mounting pin wear exceeds 5% of the original diameter, immediately replace implement pins.
4. Check all hydraulic hoses and fittings for any leaks or wear.
5. Clean away any material build up around cylinder guide ways, spring apertures and the pin engagement surfaces.



RECOMMENDED WEEKLY CHECKS

1. Thoroughly clean coupler – (Water blast recommended).
2. Check Coupler for evidence of fatigue, weld failure, cracks or stress. Do not operate with a cracked weldment.
3. Repeat daily checks above.



INSPECTION SAFETY NOTES

Report Necessary Repairs. If your daily check uncovers any item that needs attention, repair, replacement or adjustment; REPORT IT NOW! The most minor defects could result in more serious trouble. If the machine is operated, only perform the work you are authorized to do. Do not attempt repairs you do not understand.

Check for broken, defective or missing parts and replace them. Keep equipment clean and free of dirt and oil so you can spot loose or defective parts.

Any damage to the Coupler should be reported immediately to either your site manager or directly to Werk-Brau Engineered Attachments Ltd.



Annually or 1000 hrs (whichever comes first)

1. Check all pin contact surfaces for wear. Build up and machine as required.
2. Remove Jaw and Check Condition of Safety Pawls. Any sign of deformation or wear indicates the need for **REPLACEMENT**.
3. Replace the lock Pawl springs/rubbers annually.



IMPORTANT CAUTION – WELDING

Do not weld directly to the Quick Coupler without Werk-Brau approval, except for the supplied clipper plates if applicable.

Do not weld any attachment while it is connected to the coupler. This may result in internal arc damage to the actuator and cylinder and void any applicable warranty.

Always disconnect machine battery before any welding work is started.



CAUTION

Never allow a hydraulic line or component to become contaminated. This could cause severe system damage. Contact an authorized machine distributor to obtain proper caps and plugs to be used on this machine.



MAINTENANCE SAFETY NOTES

Improper operation and maintenance of this equipment could result in serious injury or death. Read the operator's manual and this book thoroughly before operating and/or maintaining this equipment.

Maintenance should only be performed by experienced and qualified personnel.

Always wear protective clothing when performing maintenance.

Avoid oil spills. Use containers, rags, and/or absorbent towels to contain any oil leakage. Dispose of all waste oils, fluids, lubricants and other hazardous waste properly.

Do not operate the machine with a defective quick coupler. Inspect the Quick Coupler and all components before starting operation. Perform any necessary repairs before operating the Quick Coupler.

Make sure the Quick Coupler and any attachments connected are resting on the ground and properly supported before performing any work on the Quick Coupler.

Unauthorized modification to the Quick Coupler or any of the Quick Coupler components may impair function, affect performance and affect the life of the quick coupler and the excavator. Unauthorized modification may impair personnel safety and will void your warranty.

Under normal conditions, all machine hydraulic circuits are under extreme pressure. When inspecting for leaks, use a small piece of cardboard, wood or metal to locate leakages. Small (pinhole) leaks can be dangerous if contact with skin or eyes is made. Wear approved safety glasses and/or face shield, gloves, hard hat, safety shoes, and work clothes during all inspection and maintenance procedures.

All coupler/attachment combinations should be checked for possible interference before using. Ensure that the coupler engages and disengages properly and easily.

Always relieve hydraulic pressure before removing hydraulic fittings.

TO REMOVE CYLINDER

Vent pressure in hydraulic lines. Disconnect at the cylinder and plug all open ports and fittings.

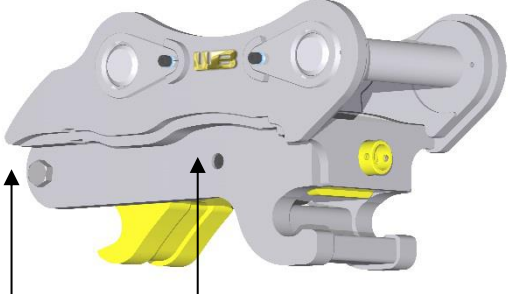
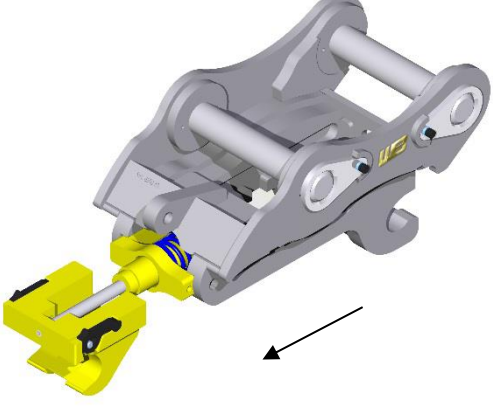
	
<p>Remove limit bolts. Remove spring locator cap screws from both sides.</p>	<p>Slide the jaw, spring locator and cylinder out the end as one. The jaw retaining pin can now be driven out to release the cylinder.</p>



To refit:

1. Slide the main spring and spring locator over the cylinder.
2. Refit the jaw pin, ensure the pawl rubbers are in place and in good condition.
3. Fit the pawls and slide assembly into hitch coupler body.
4. Insert a length of 20 x 2 flat bar or similar between the top of the jaw and the hitch opening to depress the pawls
5. Use a G clamp to pull the spring locator into alignment and fit the cap screws.
6. Remove the flat bars and refit the rear limit bolt.

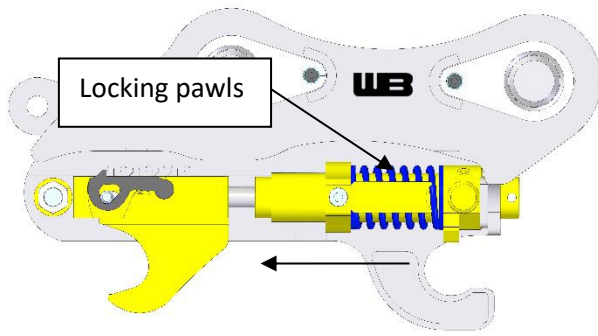

Please ensure this maintenance record is completed for any work completed on quick coupler.

Service record	Hour reading	Maintenance / Repair	Completed By	Date

PARTS LIST

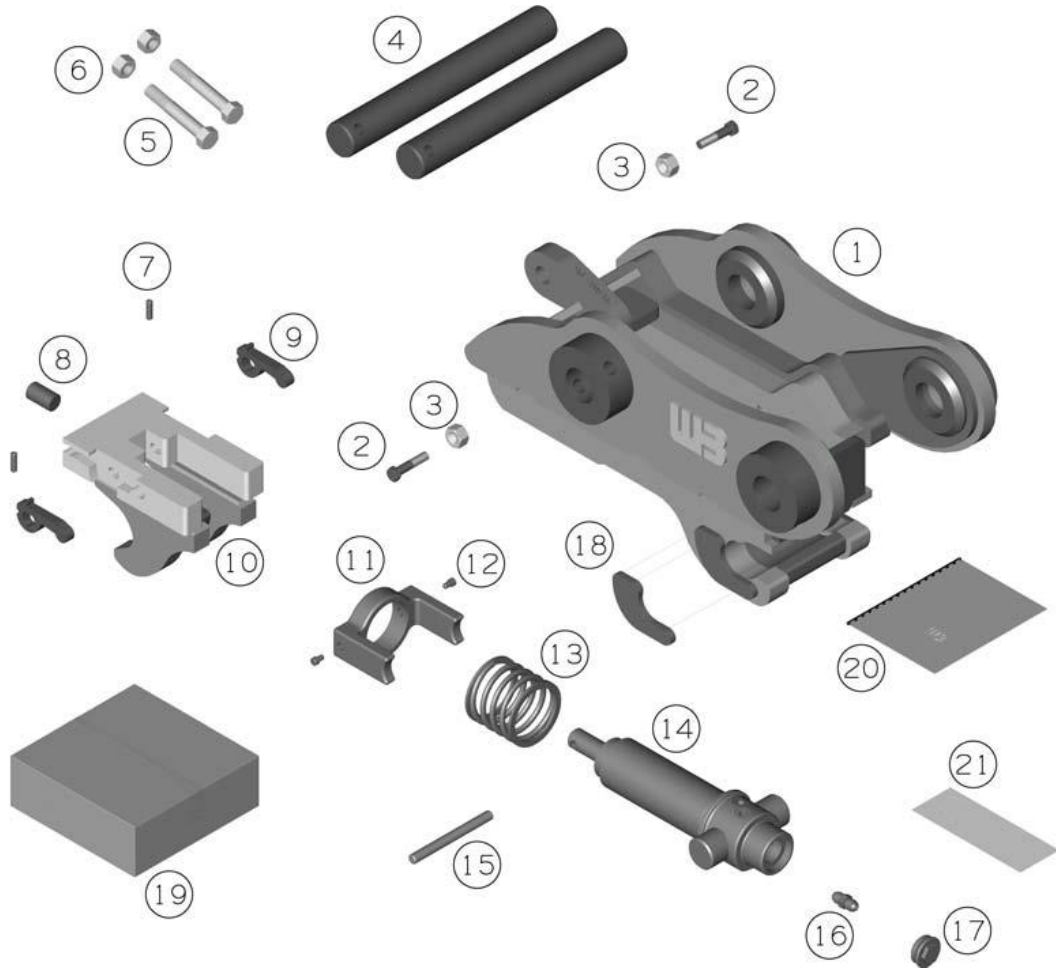

#	Description	QTY
1	Welded Assembly	1
2	Jaw Stop Bolts	2
3	Jaw Stop Nuts	2
4	Bucket Pins	2
5	Bucket Pin Bolts	2
6	Bucket Pin Nuts	2
7	Paw Spring	2
8	Jaw Grub Screw	1
9	Lock Pawls	2
10	Jaw	1
11	Spring Locator	1

#	Description	QTY
12	Spring Locator Bolt	2
13	Spring Locator Bolt	1
14	Cylinder	1
15	Cylinder Pin	1
16	Cylinder Check Valve	1
17	Cylinder Valve Cap	1
18	Clipper Plates (Opt)	2
19	Hose Kit	1
20	Instructions	1
21	Stickers	2

Customer Obligations

The Customer is responsible for the correct and proper installation of the coupler or attachment as detailed in the Operation and Maintenance documentation supplied by Werk-Brau, including hydraulic and electrical connections.

The Customer is responsible for the completion of the formal Pre-delivery check and the Warranty Registration forms (which form part of the above documentation) and their return to Werk-Brau within seven days of initial commissioning.

The Customer is responsible for ensuring that the coupler or attachment, including any hydraulic components and fittings, is operated and maintained using best industry practice and in accordance with the Operation and Maintenance documentation supplied by Werk-Brau. (a copy of which is available on request.)

The Customer is also responsible for notifying Werk-Brau as soon as it identifies a defect or problem that may potentially be subject to a claim under this policy and for following Werk-Brau's published Warranty Claim Procedure.

Warranty Claim Procedures

Visit Werk-Brau.com

Thank you for your purchase and work safe!



TOUGH JOBS DEMAND TOUGH ATTACHMENTS



WERK-BRAU CO. INC.,
2800 Fostoria Rd
P.O. Box 545
Findlay, Ohio 45839

1-800-537-9561 *phone*
419-422-7207 *fax*
Werk-Brau.com